

# Optimising fabric quality, finishing processes and machinery through the use of fabric objective measurement

---

Dr Allan De Boos  
Australian Wool Innovation



AUSTRALIAN WOOL  
TEXTILE TRAINING CENTRE



australian wool  
**innovation**  
limited



International Fibre Centre

# Lecture in two parts

---

- Part 1
  - Fabric quality – Can it be measured?
  - Fabric Objective Measurement
  - Prediction of faults – examples of faults
- Part 2
  - Optimisation of finishing operations using FOM
  - Correction of faults

# Steps in objective evaluation of finishing processes and machines

- Determine the primary effect required.
- Use objective test that measures that effect.
- Determine unwanted effects.
- Use objective test that measures unwanted effects.
- Optimise process to MAXIMIZE required effect and MINIMIZE unwanted effect.

# Presetting

- Required effects:
  - remove residual strains in fabric
  - permanently flat set the fabric.
- Appropriate tests:
  - permanent set using crease angle test (crease sewn into fabric prior to process)
  - shear properties (bias extensibility using SiroFAST-3).

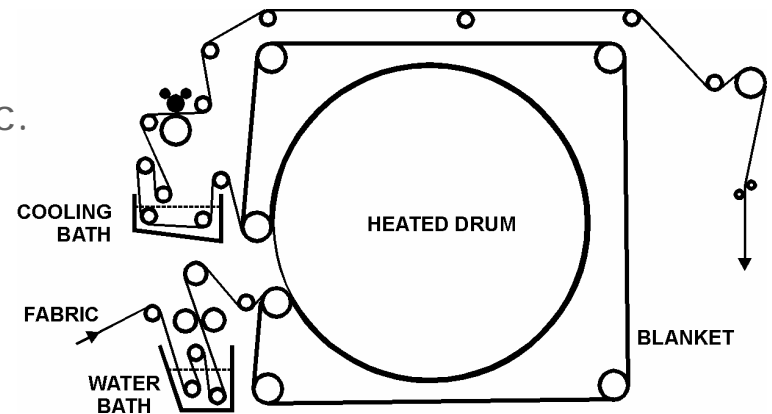

# Presetting

- Side effects:
  - stretch the fabric (especially in the warp direction)
  - compact the fabric in the weft – loss of width.
- Appropriate tests:
  - warp and weft dimensions
  - warp and weft extensibility
    - **SiroFAST-3.**

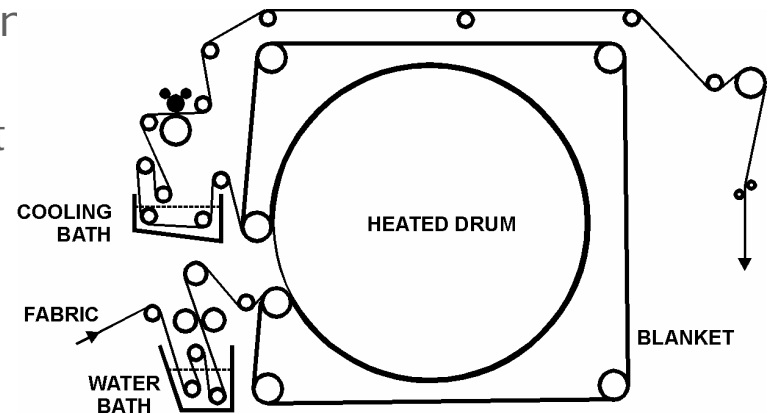

# Scouring

- Required effect:
  - clean the fabric.
- Appropriate test:
  - residual oil/grease.

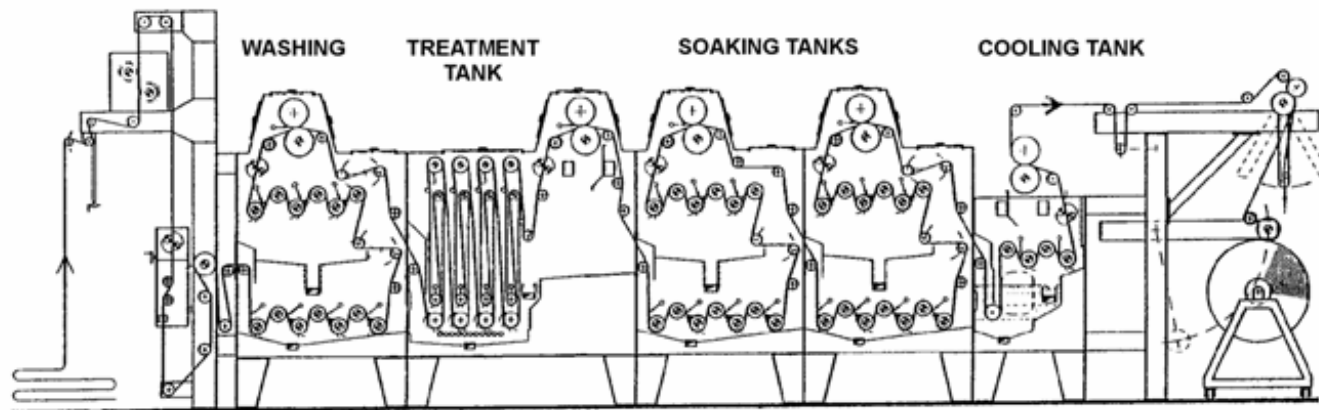

# Scouring

- Side effects:
  - uncontrolled relaxation leading to puckering
  - stretching in warp direction
  - Felting.
- Appropriate tests:
  - visual assessment
  - fabric dimensions
  - fabric extensibility
    - SiroFAST-3
  - fabric thickness
    - SiroFAST-1.

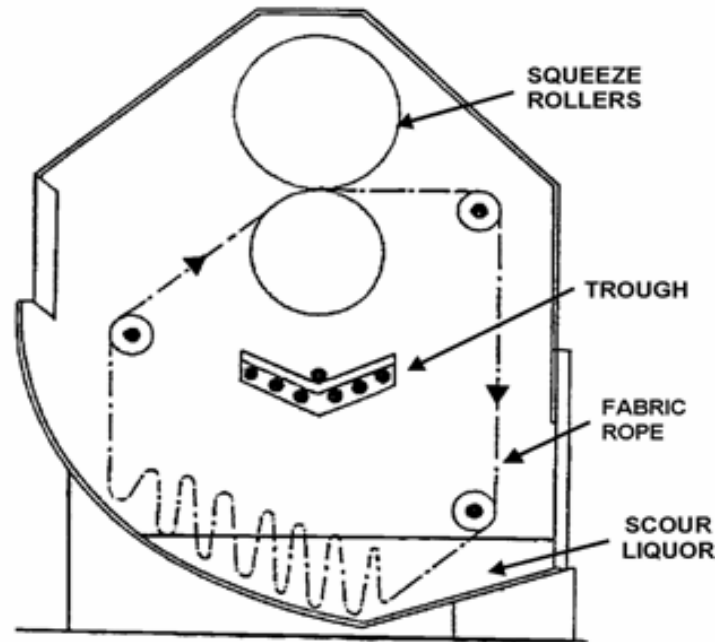

**Will this rope scour stretch the fabric less than the continuous scour? Why?**

# Fabric development

- Required effects:
  - softer handle
  - reduction in hygral expansion.
- Appropriate tests:
  - fabric thickness (SiroFAST-1)
  - bias extensibility (SiroFAST-3)
  - hygral expansion (SiroFAST-4).

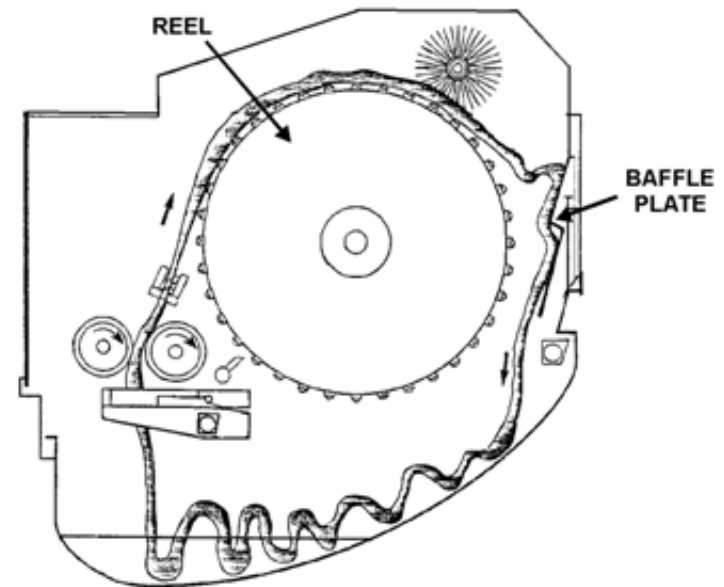



# Fabric development

---

- Side effects:
  - stiffening
  - surface modification
  - formation of running marks.
- Appropriate tests:
  - shear rigidity/bias extensibility
  - surface thickness
  - visual observation.



# Milling

- Required effects:
  - surface modification, especially surface cover
  - increased strength
  - stiffening
  - reduction in hygral expansion.
- Appropriate tests:
  - fabric thickness (SiroFAST-1)
  - tensile test
  - shear rigidity-bias extensibility (SiroFAST-3)
  - hygral expansion (SiroFAST-4).

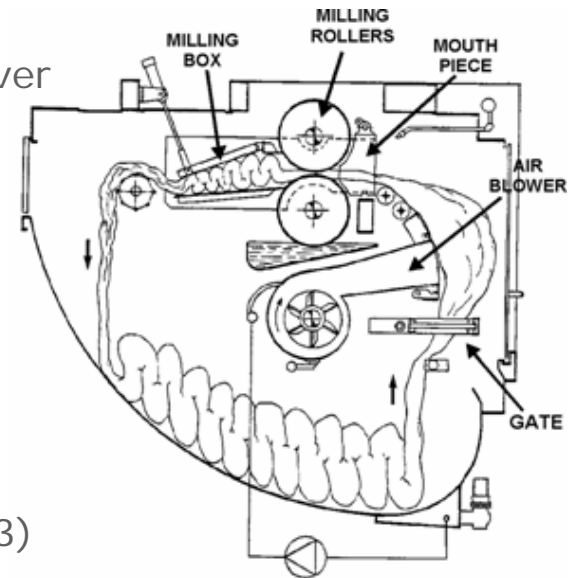

# Milling

---

- Side effects:
  - running marks.
- Appropriate tests:
  - visual inspection after relaxation.
- Solutions to running marks:
  - when imparted, difficult to remove.
- Prevention:
  - set or relax fabric prior to milling
  - re-lay the fabric during process
    - air blowers
    - double gating.
- Correction of running marks:
  - flat set (effectively) fabric after milling
    - crab (still wet)
    - wet decatise
    - pressure decatise.

# Piece dyeing

---

- Required effects:
  - colouration.
- Appropriate tests:
  - colour measurement for shade
  - visual inspection for evenness
  - fastness tests
    - wash fastness
    - perspiration fastness
    - rubbing fastness.
- Side effects:
  - permanent setting
  - increase in hygral expansion
  - uncontrolled relaxation.
- Appropriate tests:
  - permanent set using crease angle
  - hygral expansion (SiroFAST-4).

# Piece dyeing

---

- Jacket with high hygral: expansion after dyeing
  - all-wool gaberdines
  - all-wool plain weaves.
- Solutions:
  - dye using anti-setting agents
  - light mill after dyeing
  - stretch and pressure decatise.



# Drying

- Required effects:
  - reduction in moisture
  - temporary setting of fabric dimensions
  - control/*engineering* of relaxation shrinkage
  - control/*engineering* of fabric extensibility.
- Appropriate tests:
  - moisture content
  - fabric dimensions
  - fabric extensibility (SiroFAST-3)
  - relaxation shrinkage (SiroFAST-4).

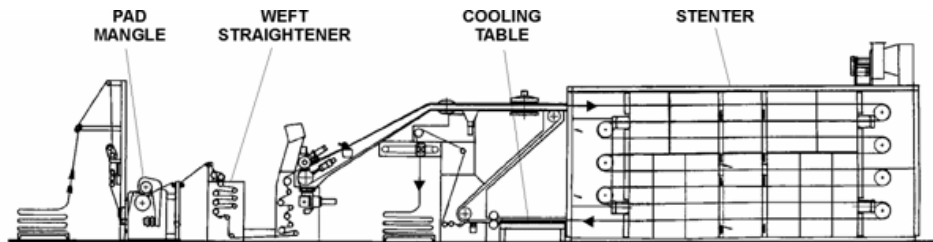

# Cropping - shearing

- Required effects:
  - removal of surface fibre.
- Side effects:
  - warp stretching (minor).
- Appropriate tests:
  - visual inspection.

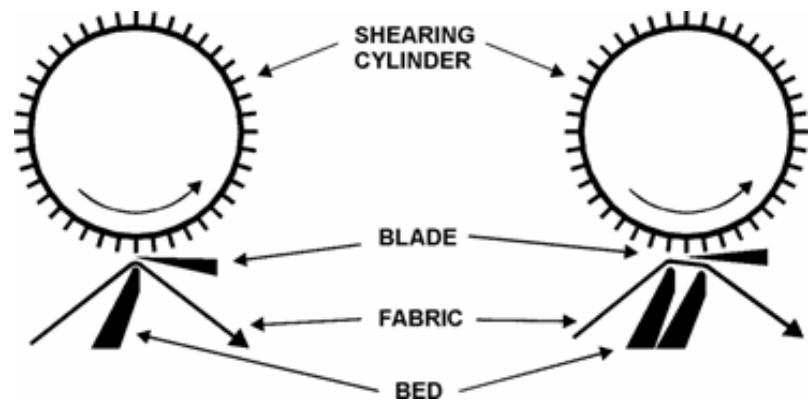

# Conditioning

- Required effects:
  - increase moisture content of fabric
  - increased permanent set in decatizing
  - improved pressing performance after decatizing.
- Appropriate measurements:
  - moisture content
  - permanent set using crease angle
  - press test angle.

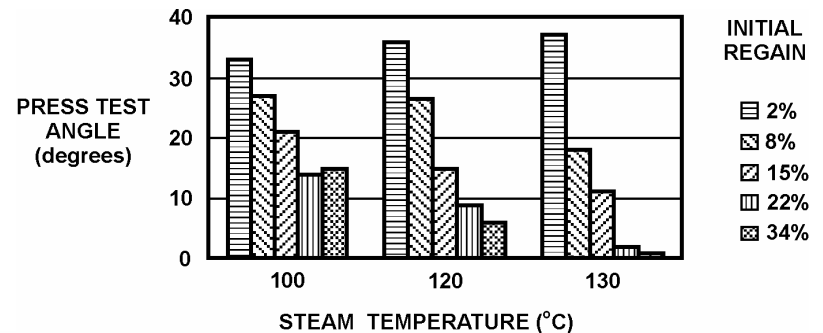
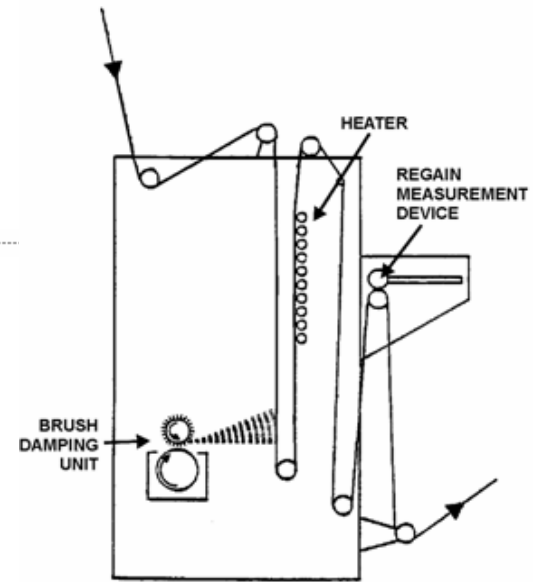



# Conditioning

---

- Unwanted effects:
  - release of temporary set
  - reappearance of running marks.
- Appropriate tests:
  - increase in surface thickness (SiroFAST-1).

# Pressing

- Required effects:
  - flatten fabric (temporary set)
  - smoother handle.
- Appropriate tests:
  - fabric thickness, surface thickness (SiroFAST-1)
  - surface contour (KES-F4)
  - surface friction (KES-F4).

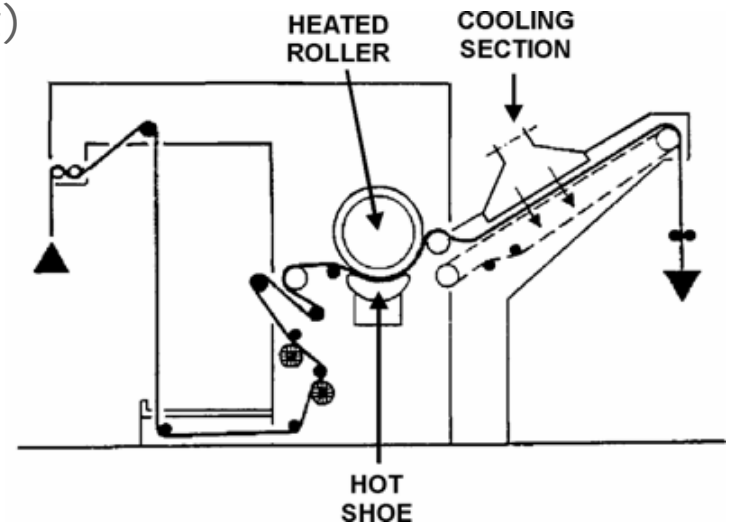

# Pressing

- Side effects:
  - stretching fabric in warp direction.
- Appropriate tests:
  - warp dimensions
  - warp relax
  - shrinkage
  - warp extensibility.

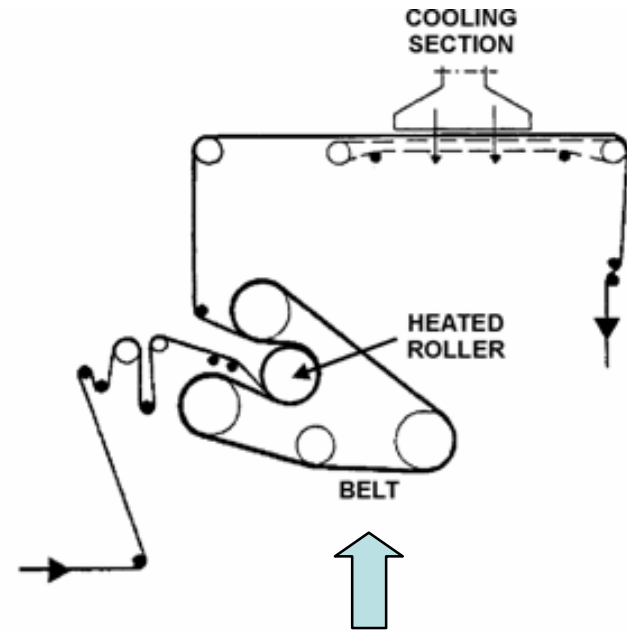

Belt press

Will this stretch the fabric more or less than the rotary press ?

# Decatising

- Required effects:
  - *permanently* flat set the fabric
  - improve dimensional stability
  - improve suppleness
  - improve smoothness.
- Appropriate tests:
  - crease angle test
  - relaxed surface thickness (SiroFAST-1)
  - relaxation shrinkage (SiroFAST-4)
  - bias extensibility (SiroFAST-3)
  - surface thickness (SiroFAST-1)
  - surface contour and friction (KES-F4).

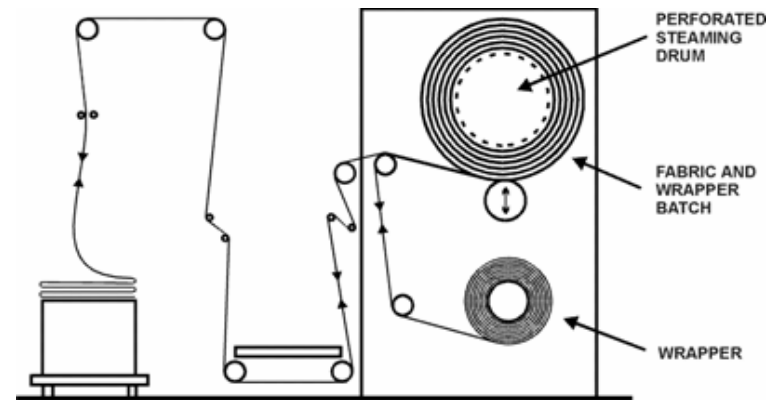

# Decatising

- Side effects:
  - uneven treatment (end-to-end)
  - stretch in warp direction
  - yellowing.
- Appropriate tests:
  - bias extensibility (end-to-end)
  - thickness (end-to-end)
  - air permeability (end-to-end)
  - warp dimensions
  - warp extensibility (SiroFAST-3)
  - colour/yellowness.

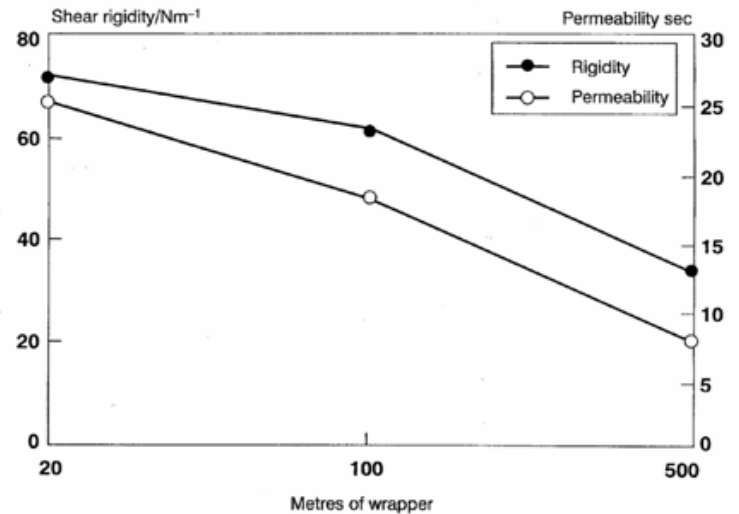

# Relaxation - sponging

- Required effects:
  - reduce relaxation shrinkage
  - reduce lustre.
- Appropriate tests:
  - relaxation shrinkage (FAST-4)
  - fabric dimensions
  - surface thickness (SiroFAST-1).

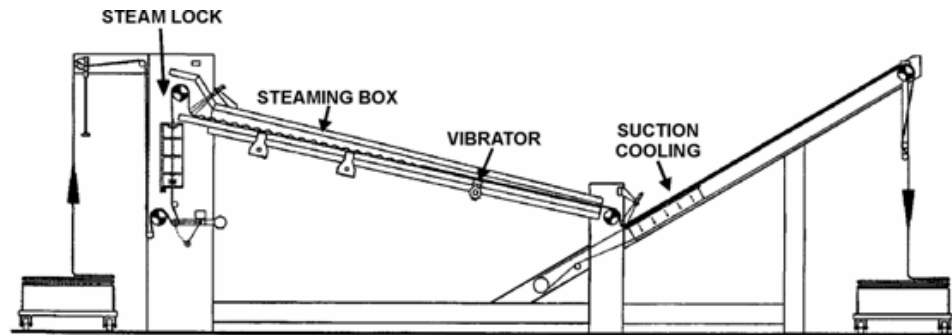

# Relaxation - sponging

- Side effects:
  - remove surface finish
  - stretching.
- Appropriate tests:
  - surface thickness (SiroFAST-1)
  - warp dimensions
  - relaxation shrinkage (SiroFAST-4).

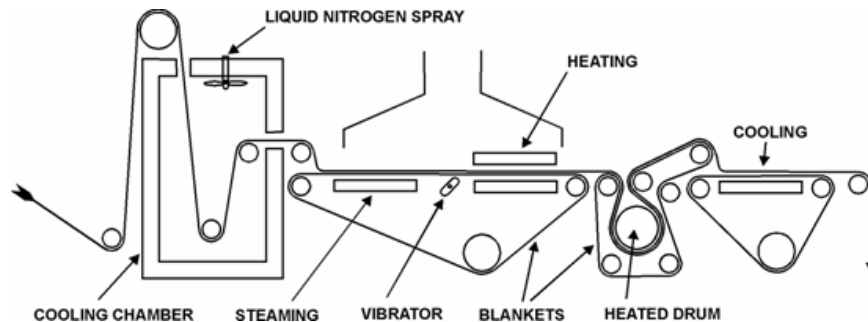

Juki Sponger.

Will this relax the fabric more effectively than the steam table? Why?

# Raising

---

- Required effects:
  - increase in surface fibre
  - increase in thickness.
- Appropriate tests:
  - surface thickness
  - fabric thickness (SiroFAST-1).
- Side effects:
  - stretching of fabric in warp direction
  - increase in warp relaxation shrinkage.
- Appropriate test:
  - warp dimensions
  - warp extensibility (siroFAST-3)
  - relaxation shrinkage (SiroFAST-4).

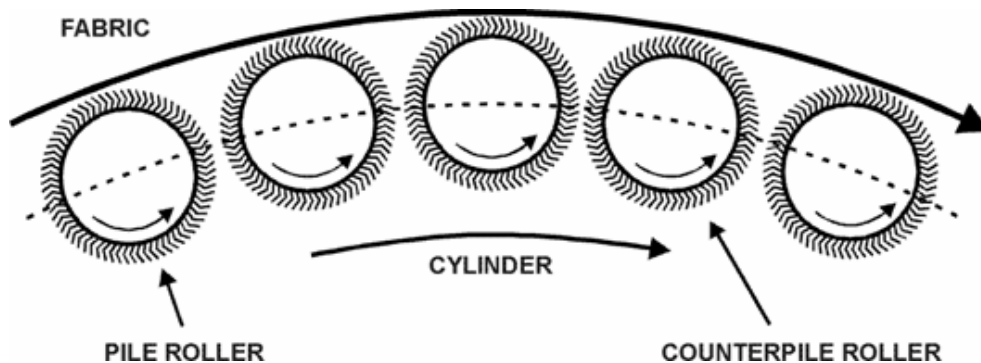



# Summary

---

- Most wool finishing processes and machinery can be objectively evaluated.
- The quantitative data takes much of the subjectivity out of decisions.
- A range of test procedures can be used to measure both desirable and unwanted effects.

# Key properties affecting quality that can be controlled in finishing

Fabric type	Colour-woven light-weight	Milled flannel	Piece dyed gaberdine	Woollen
<i>Weight</i>	X	(X)	(X)	(X)
Relaxation shrinkage	X	XX	XX	XX
Hygral expansion			XX	
Finish stability		XX	XX	XX
Press test angle	XX	X		
Warp formability	XX	X		